

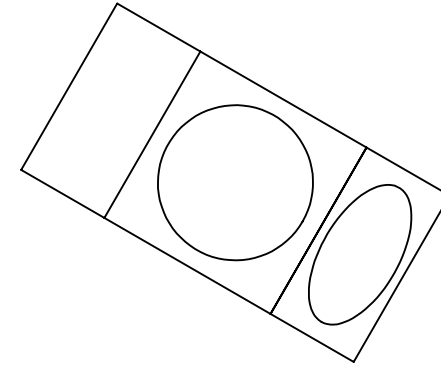

THE INFORMATION CONTAINED IN THIS DRAWING IS THE SOLE PROPERTY OF PRECISION PHOTONICS CORPORATION. IT IS DISCLOSED IN CONFIDENCE AND MAY NOT BE COPIED, REPRODUCED, USED OR DISCLOSED IN WHOLE OR IN PART WITHOUT PROPER WRITTEN CONSENT OF PRECISION PHOTONICS CORPORATION.

- NOTES:  
 1. PART TO BE FREE OF OILS AND CONTAMINATES  
 2. EDGE BEVEL TO BE: <0.1MM

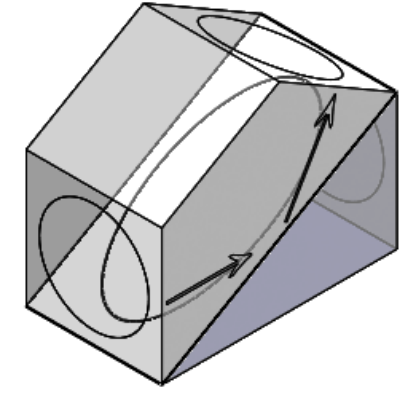
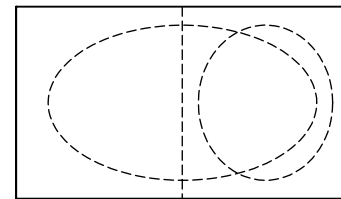
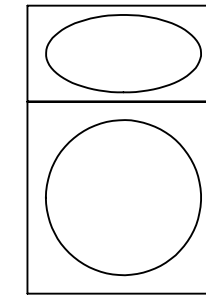
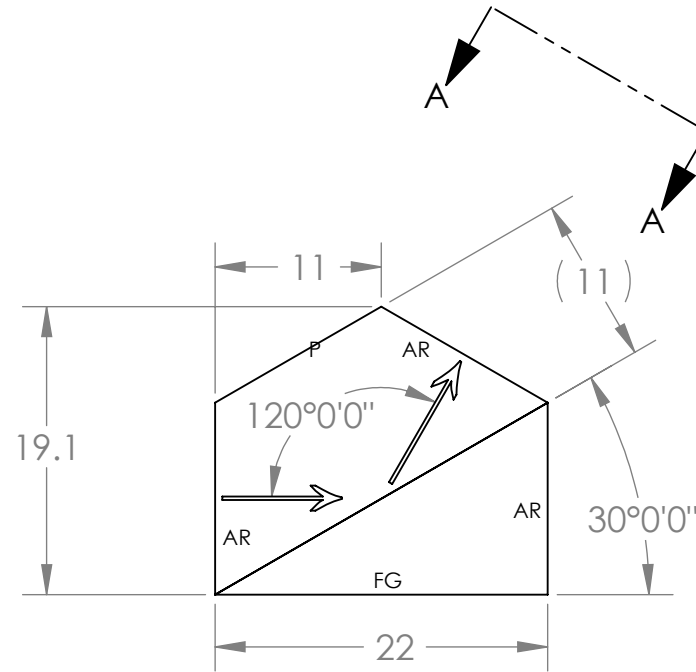
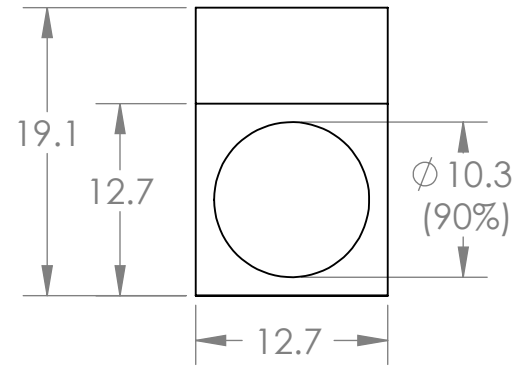

VIEW A-A



UNLESS OTHERWISE SPECIFIED DIMENSIONS ARE IN MILLIMETERS TOLERANCES ARE: X ±0.1 X.X ±0.05 ANGLES ±1/2 DEG FRACTIONS ±1/32 MACHINED SURFACE FINISH: 32 INTERPRET DWG. PER ASME 14.5M-1994 THIRD ANGLE PROJECTION	CAD GENERATED DRAWING, DO NOT MANUALLY UPDATE			
	APPROVALS	DATE		TITLE
	DRAWN B.BALLAGH	TBD		
	CHECKED			
MATERIAL	RESP ENG B.BALLAGH			
	FINISH TBD			
USED ON	DO NOT SCALE DRAWING	CAD FILE: LGVD CUBE	SIZE B DWG NO LGVD CUBE REV A SCALE 2:1 SHEET 1 OF 1	